



Balco Twin[®]



Care advice and instructions for use



Congratulations on your new glazed balcony

We at Balco thank you for your custom and warmly welcome you to your outdoor room. To get the best possible use out of your new space, we would ask you to read through the care instructions. If you move home, please pass this information on to the new occupant.

Cleaning the lower track profile

The lower track profile of the glazing system drains water through drainage holes in the base of the profile. The profile, track and drainage holes can be vacuumed or wiped down with a cloth. At the join with the outer posts, there are also drain covers that can be removed with a screwdriver or knife if they need to be cleaned of any rubbish.

Cleaning the windows

The panes can be cleaned just like normal windows, either with water or window cleaner. Avoid alkaline window cleaners.

Cleaning aluminium profiles and laminate panels

Clean with liquid soap, washing-up liquid or a similar cleaner. Do not use solvents such as paint thinner, as it may cause damage to the laminate and lacquered profiles. The only solvent that can be used is methylated spirit, applied with care.

Cleaning the balcony floor

Clean the balcony floor with a normal soapy scourer. Do not use salt-based products, as they can damage the balcony floor.

Replacing glass, laminate panels

The above and other parts should only be replaced by authorised fitters.

Roller blinds

Roller blinds may only be fitted to the window sections, by Balco-authorised fitters. The chain is used to pull the roller blinds up and down. The roller blinds must be dry when they are rolled up and should also be rolled up when the windows are open. Clean with a damp cloth.

Adverse weather conditions

In adverse weather conditions, strong winds combined with rain or snow may cause some water penetration. However, this will have no

damaging effect on the materials. If the temperature is so low that the water around the windows has frozen, avoid sliding the windows, as this may damage the brushes along their edges.

Condensation

The self-ventilating design of the glazing unit should keep the windows free of condensation. However, some condensation may occur in adverse weather conditions. In this case, you can open the windows slightly at the sides to allow the damp air to escape.

Do not drill into the frame

Since water is drained away inside the profiles, drilling may lead to leaks.

Do not cover the ventilation gap!

For good ventilation and to ensure air supply to the building's ventilation system, the air gap between the window and the ceiling must not be covered.

Hanging

Lamps and so on must be fitted to the wall of the apartment. Do not fit anything to the balcony roof, as this is made of material that must not be drilled into.

The glazing system is not designed for satellite dishes or window boxes from suppliers other than Balco.

Awnings may only be installed by Balco-approved fitters, and on condition that the window is pre-prepared for the installation of awnings. (optional extra)

Damage

If any damage occurs, contact your caretaker, who has information about repairing paint damage and other damage of a similar nature. If major damage occurs, the caretaker will contact the supplier.

HOW TO OPEN ANY WINDOW

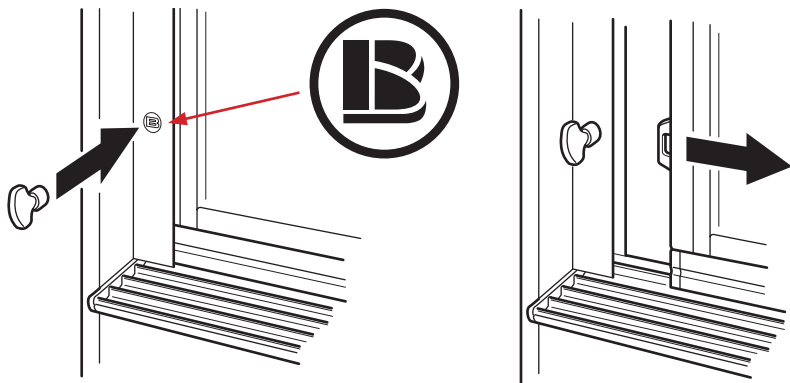

- ① Place the magnet against the area marked 'B'.
- ② The window unlocks automatically when the magnet attaches to the marked area. Keep the magnet in place.

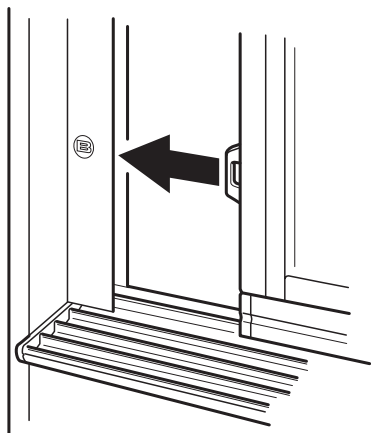

When you want to close the window, return it to the starting position. NOTE: The window will not lock until you remove the magnet.

FOR MAXIMUM OPENING

The description relates to windows opening from the right-hand side. The illustrations show the opening function from above.

- ① Slide the window in the outer track to the left and the other windows to the right.
- ②a Lift the handle and open the window towards you.
- ②b Open the window fully.
- ③ Then slide the next window from right to left.
- ④ Open as described above.
- ⑤ Repeat this procedure until all the windows are open.

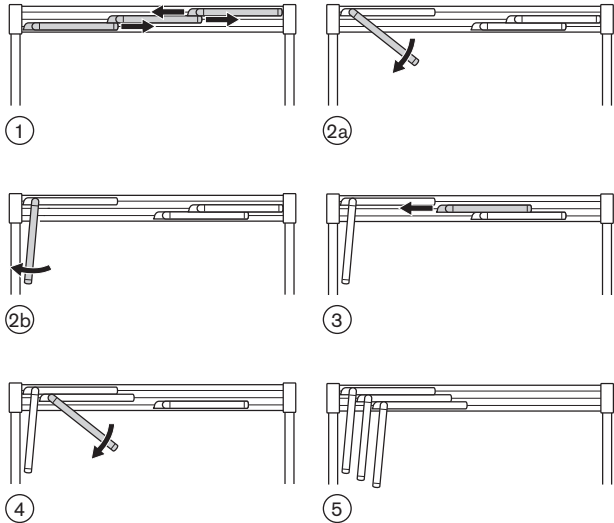

If the handle is located on the left of the windows, slide the outer window to the right and the other windows to the left. Then apply the same principle for maximum opening as described above.

Sweden (HQ)

Balco AB
Älgvägen 4
352 45 Växjö
Phone +0470-53 30 00
Telefax +0470-53 30 97
balco@balco.se
www.balco.se

Norway

Balco AS
Sandstuveien 60A
1184 Oslo
Phone +47 23 38 12 00
Telefax +47 23 38 12 01
balco@balco.no
www.balco.no

Denmark

Balco A/S
Industriholmen 15 B
2650 Hvidovre
Phone +45 57 83 13 50
Telefax +45 57 83 43 50
balco@balco.dk
www.balco.dk

Germany

Balco Balkonkonstruktionen GmbH
Ernst-Ruska-Ufer 2
12489 Berlin
Phone +49 30 634 998 25
Telefax +49 30 634 998 24
balco@balco.de
www.balco.de

UK

Balco Balcony Systems Ltd
11 Waltham Court, Milley Lane
Hare Hatch
READING
RG10 9AA
Phone +44 (0) 2036 871020
balco@balcouk.com
www.balcouk.com

The Netherlands

Balco Balkonsystemen B.V.
Ommelseweg 44d
5721 WV Asten
Phone +31 (0) 493 698 098
balco@balco.nl
www.balco.nl