

Aluminium Decking

Product information and Specifications





Available in a wide range of RAL colours

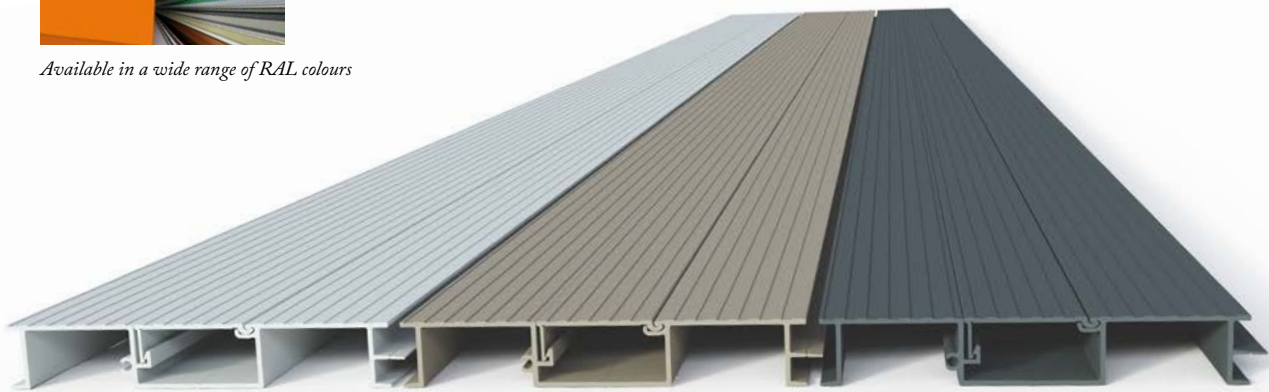

RAL 7040 - Window grey

RAL 7039 - Quartz grey

RAL 7016 - Anthracite grey

Aluminium Decking

In line with BS 8579:2020 guidance, Balco provide a well-engineered and non-combustible aluminium deck system, whilst also providing the end-user with a durable, long-lasting and low maintenance product. The decking boards are specially developed to withstand all weathering conditions, with a hard-wearing and anti-slip surface.

- Coarser particle texture for improved slip resistance in dry and wet conditions
- ≥ 60 PTV (dry) and ≥ 50 PTV (wet) in accordance with BS7976-2 +A1 2013 (solid colors)
- A2fl or A2,s1-d0 classified
- Qualicoat Class 1 & 2 compliant
- Minimum order quantity of 50kgs for solid shades
- Complies with Part B UK building regulations
- No warping or rotting issues associated with traditional timber decking

Easily assembled, Balco's decking has been designed for every application, and works seamlessly with Balco's Levitate® balcony drainage system, ensuring compliance with recognised Guarantee Providers.

Balco's decking is available in three Classic RAL colours as standard, although other colours can be considered

- Sustainable & recyclable material
- Reduced maintenance
- Qualicoat coating material compliant with EN 12206
- Improved aesthetics

Independant tests also meet or exceed:

- ISO 1519 (cylindrical Mandrel)
- ISO 2409 (2mm crosshatch)
- ISO 1520
- ISO 6272:1993
- ISO 2815

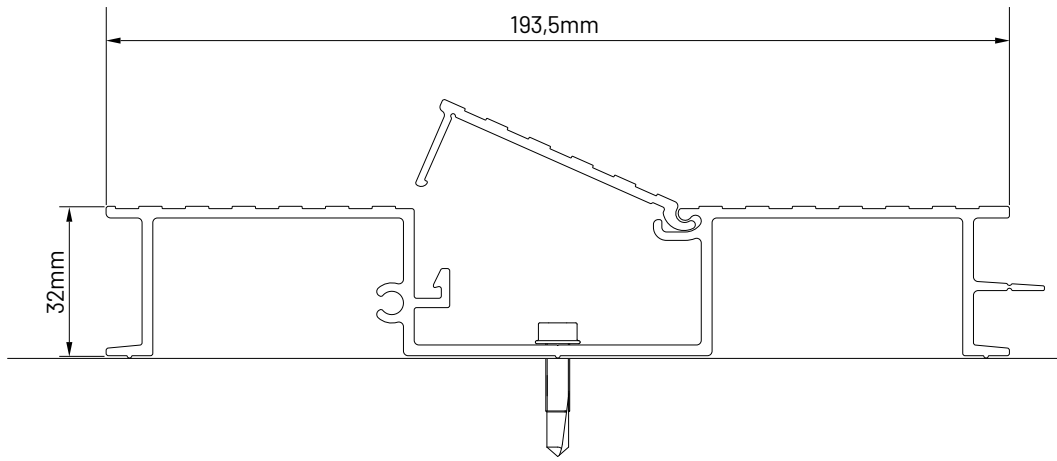

After the main profile is fastened, the open section is covered by clicking the secondary profile into place.

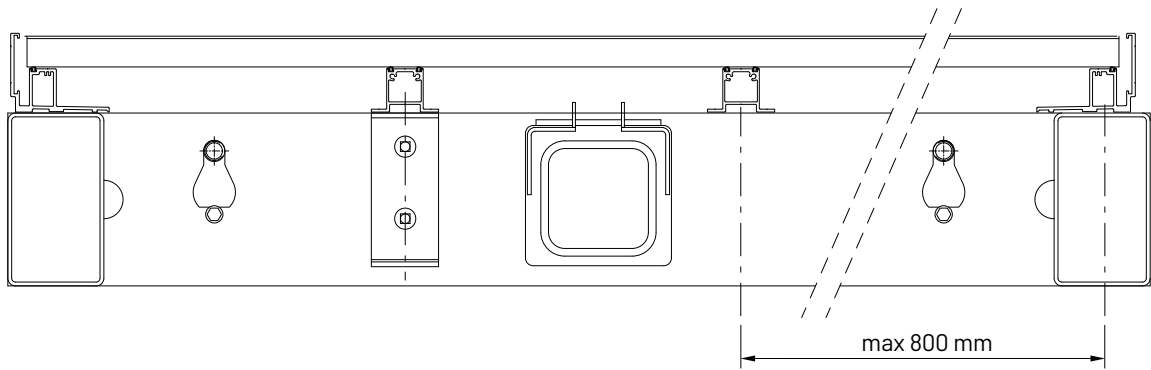

3

Free span width for the aludecking profiles is 800mm, which fulfills the load resistance and deflection requirements found in BS8579:2020

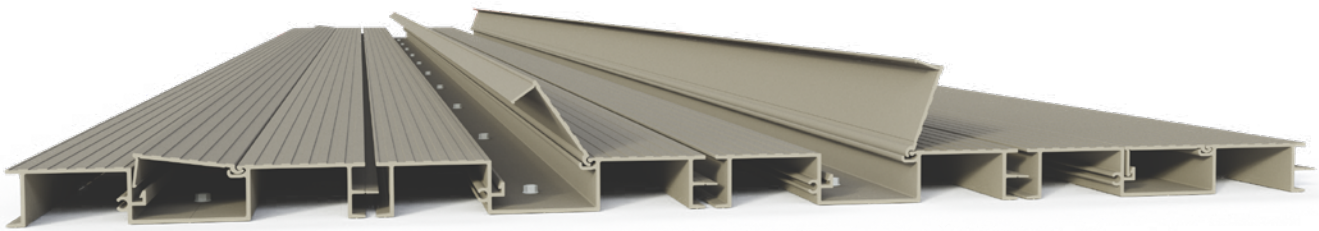

*Europe's leading provider
of end-to-end balcony solutions.
Balconies for greater living.*

www.balcouk.com



Balco Balcony Systems Ltd

The Wagon House, Prockters Farm
West Monkton, Taunton TA2 8QN
United Kingdom

Phone +44 (0)2036 871020



BALCONIES
FOR
GREATER
LIVING